

Resources		
Resource	Material	QTY
1	1/2" Plywood	
2	3/4" Plywood	
3	1/2" Plastic	
4	Wood Glue	As Needed
5	Staples	As Needed
6	Wood Screws	As Needed

PARTS LIST			
ITEM	QTY	PART NUMBER	DESCRIPTION
1	2	RC-00701-10	Top / Bottom
2	6	RC-00701-11	Top, Short Dividers
3	6	RC-00701-12	Short Horizontal Divider
4	6	RC-00701-13	Long Horizontal Dividers
5	12	RC-00701-14	Vertical Support
6	4	RC-00701-15	Large Bottom Plastic
7	4	RC-00701-16	Small Bottom Plastic
8	1	RC-00701-17	Back Stop
9	4	RC-00701-18	Vertical Support w/out holes

DRAWN mcyr	7/16/2012	FIRST 200 Bedford Street, Manchester, NH 03101 (603) 666-3906 -- FAX (603) 666-3907		
CHECKED				
UNLESS OTHERWISE SPECIFIED TOLERANCES: (INCHES)		TITLE		
FRAC.	+/- 1/32	End Panel Case Insert		
.00	+/- .01	SIZE	DWG NO	REV
.000	+/- .005	C	RC-00701	
ANGULAR	+/- .25 Deg.	SCALE	SHEET 1 OF 9	

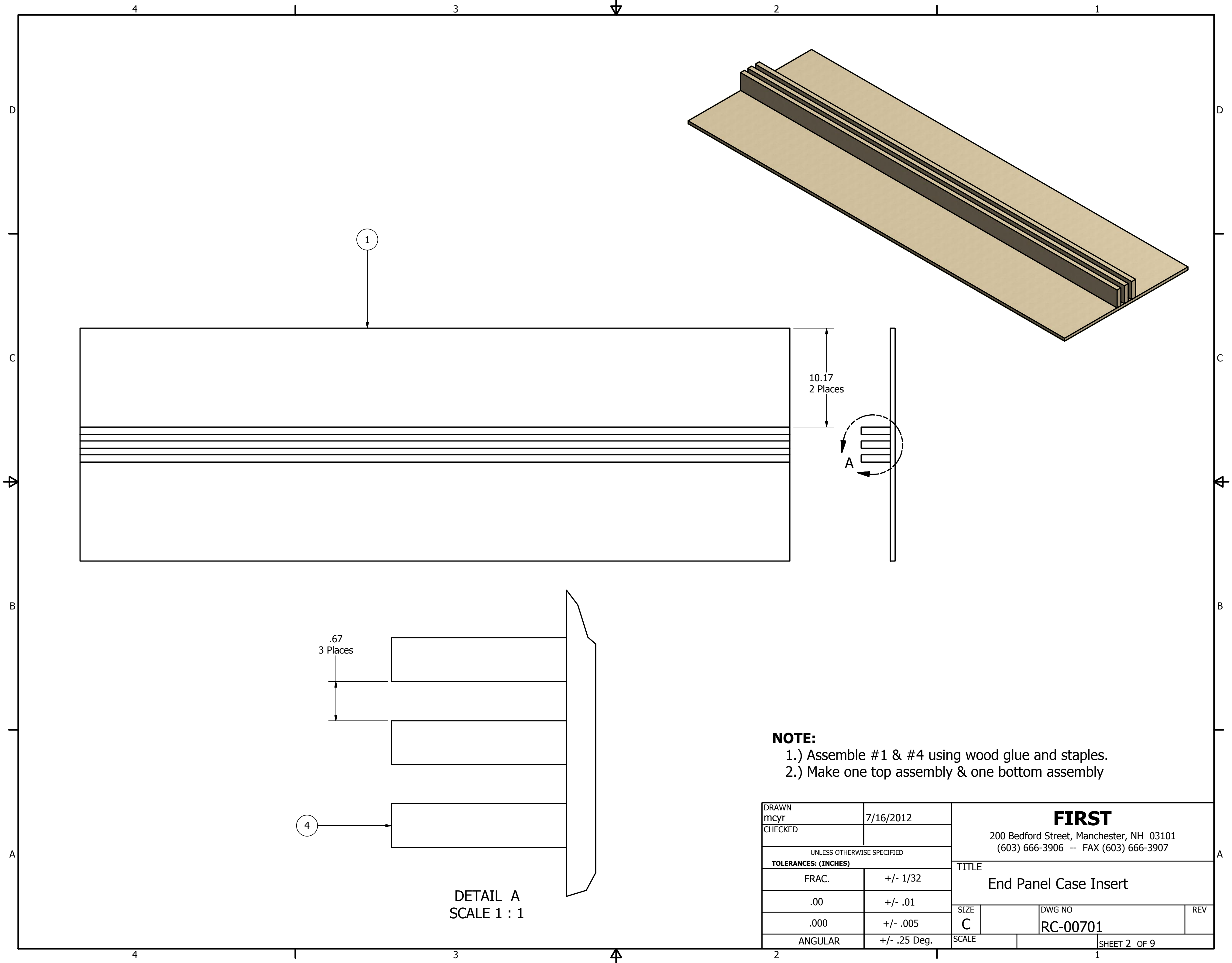

NOTE:
 1.) Assemble #1 & #4 using wood glue and staples.
 2.) Make one top assembly & one bottom assembly

DRAWN mcyr	7/16/2012	FIRST 200 Bedford Street, Manchester, NH 03101 (603) 666-3906 -- FAX (603) 666-3907		
CHECKED				
UNLESS OTHERWISE SPECIFIED TOLERANCES: (INCHES)		TITLE End Panel Case Insert		
FRAC.	+/- 1/32	SIZE	DWG NO	REV
.00	+/- .01	C	RC-00701	
.000	+/- .005	SCALE	SHEET 2 OF 9	
ANGULAR	+/- .25 Deg.			

DETAIL A
SCALE 1 : 1

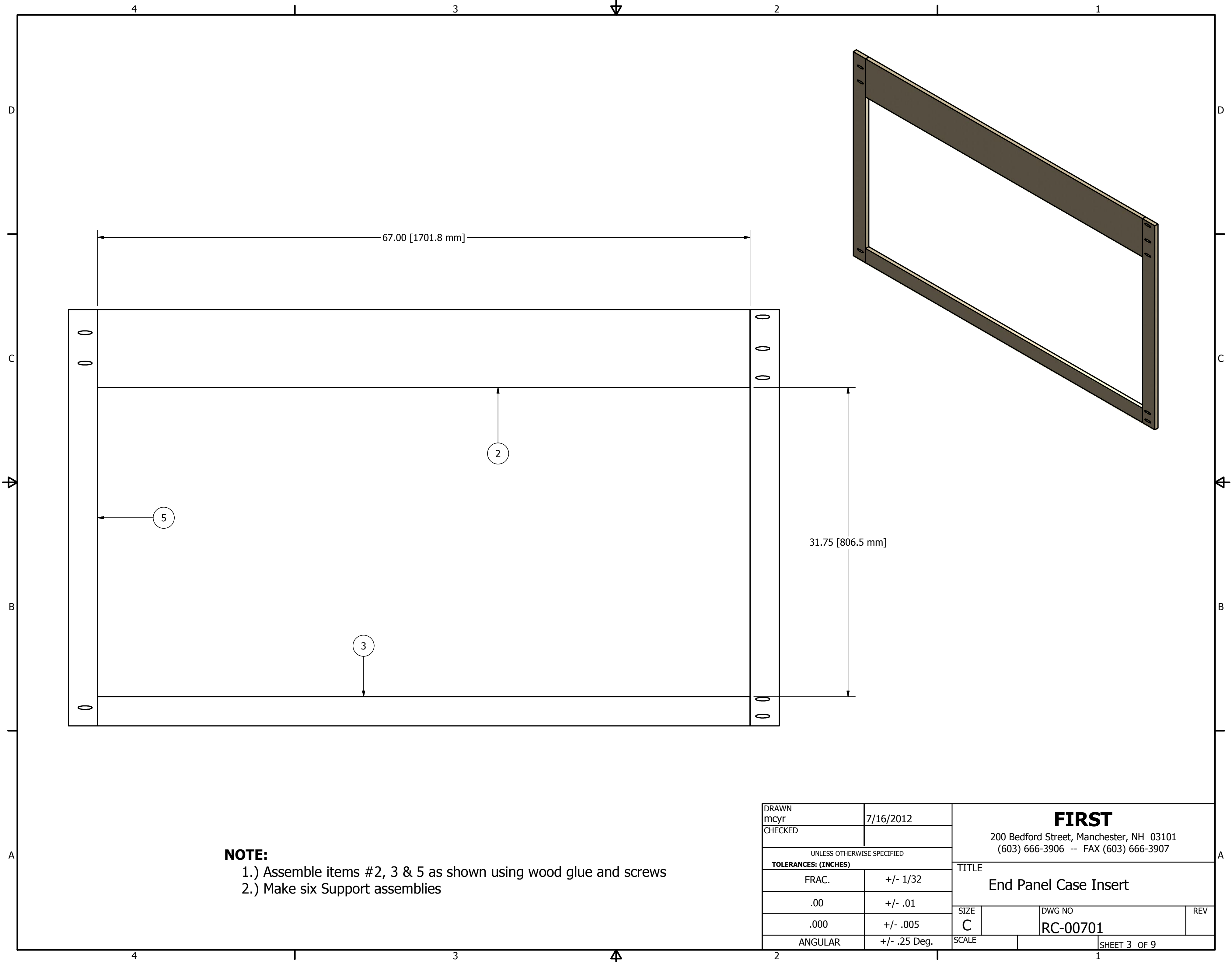

NOTE:
 1.) Assemble items #2, 3 & 5 as shown using wood glue and screws
 2.) Make six Support assemblies

DRAWN mcyr	7/16/2012	FIRST 200 Bedford Street, Manchester, NH 03101 (603) 666-3906 -- FAX (603) 666-3907		
CHECKED				
UNLESS OTHERWISE SPECIFIED TOLERANCES: (INCHES)		TITLE End Panel Case Insert		
FRAC.	+/- 1/32	SIZE	DWG NO	REV
.00	+/- .01	C	RC-00701	
.000	+/- .005	SCALE		
ANGULAR	+/- .25 Deg.			SHEET 3 OF 9

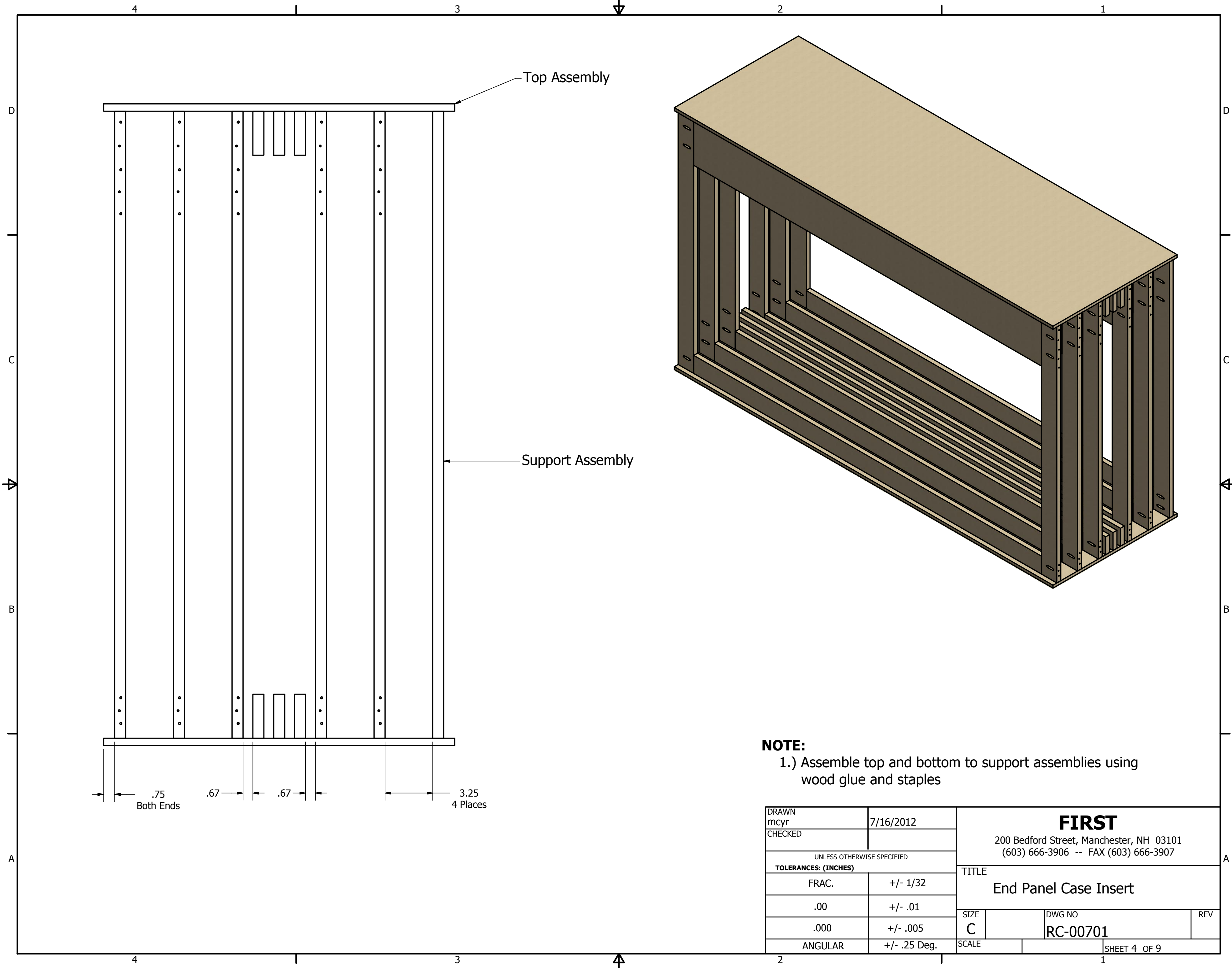

NOTE:
 1.) Assemble top and bottom to support assemblies using wood glue and staples

DRAWN mcyr	7/16/2012	FIRST 200 Bedford Street, Manchester, NH 03101 (603) 666-3906 -- FAX (603) 666-3907		
CHECKED				
UNLESS OTHERWISE SPECIFIED		TITLE		
TOLERANCES: (INCHES)		End Panel Case Insert		
FRAC.	+/- 1/32	SIZE	DWG NO	REV
.00	+/- .01	C	RC-00701	
.000	+/- .005	SCALE	SHEET 4 OF 9	
ANGULAR	+/- .25 Deg.			

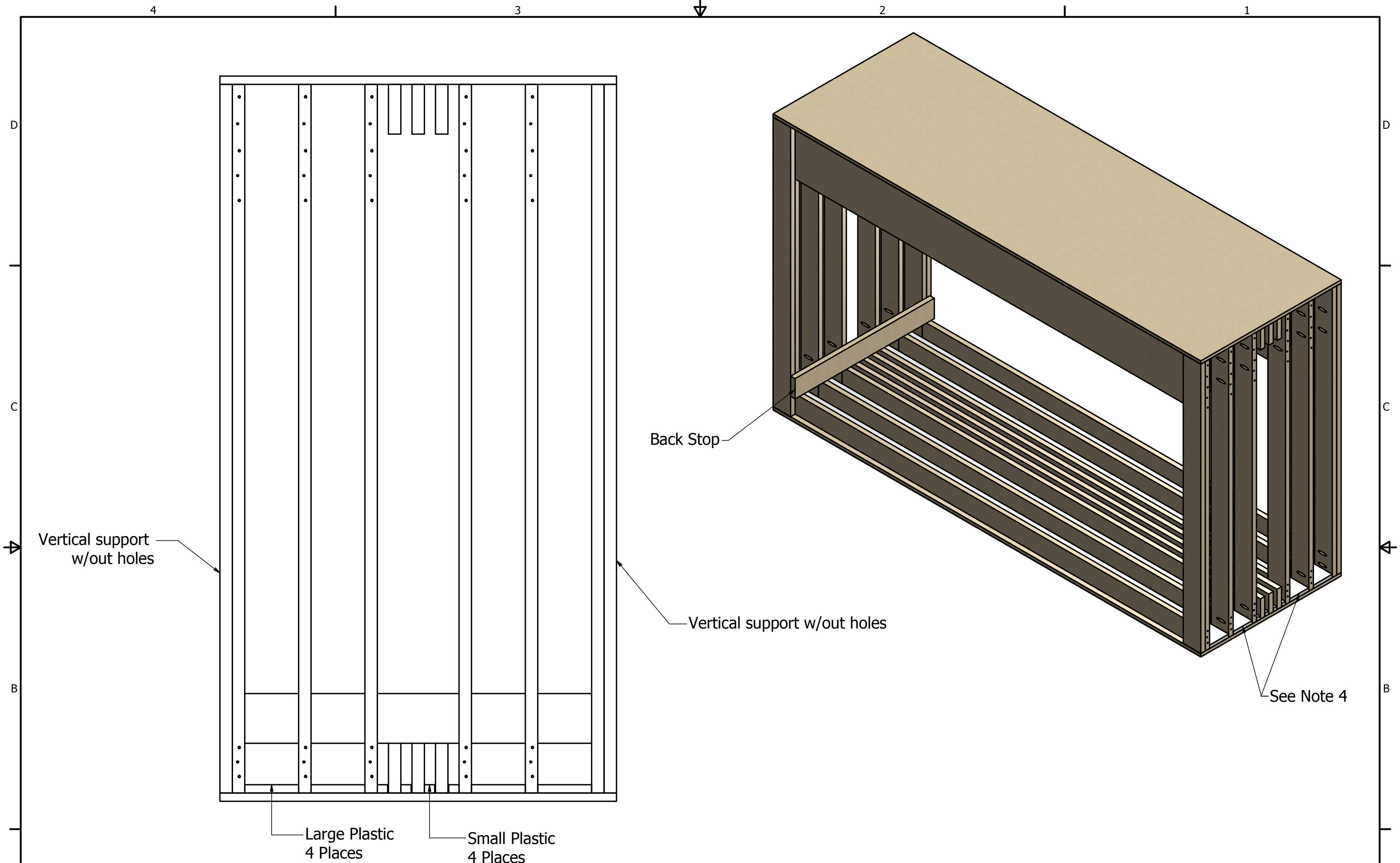

- NOTE:**
- 1.) Screw the vertical support w/out holes to the vertical support using wood screws
 - 2.) Screw Back Stop as shown using wood screws
 - 3.) Screw plastic to the bottom of each channel using wood screws
 - 4.) Do not add the front screws in this location yet. Once insert is installed in the roadcase use screws to attach insert to the bottom of the roadcase so it cannot slide out.

DRAWN mcyr CHECKED		7/16/2012		FIRST 200 Bedford Street, Manchester, NH 03101 (603) 666-3906 -- FAX (603) 666-3907		
UNLESS OTHERWISE SPECIFIED TOLERANCES: (INCHES)						
FRAC.			+/- 1/32	SIZE	DWG NO	REV
.00			+/- .01	C	RC-00701	
.000			+/- .005			
ANGULAR			+/- .25 Deg.	SCALE	SHEET 5 OF 9	

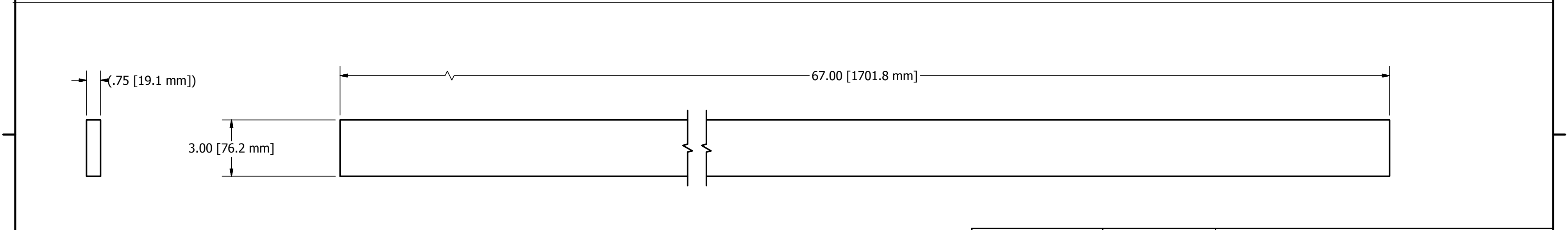
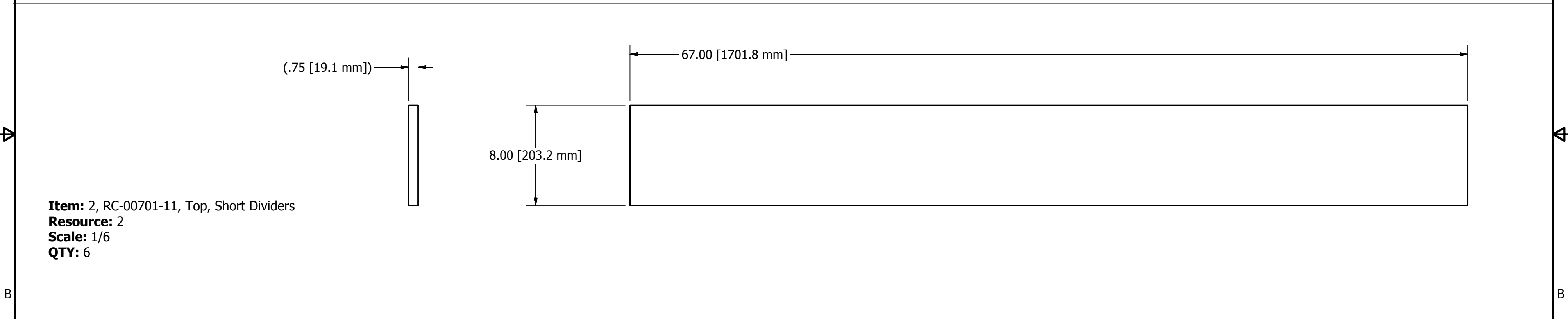
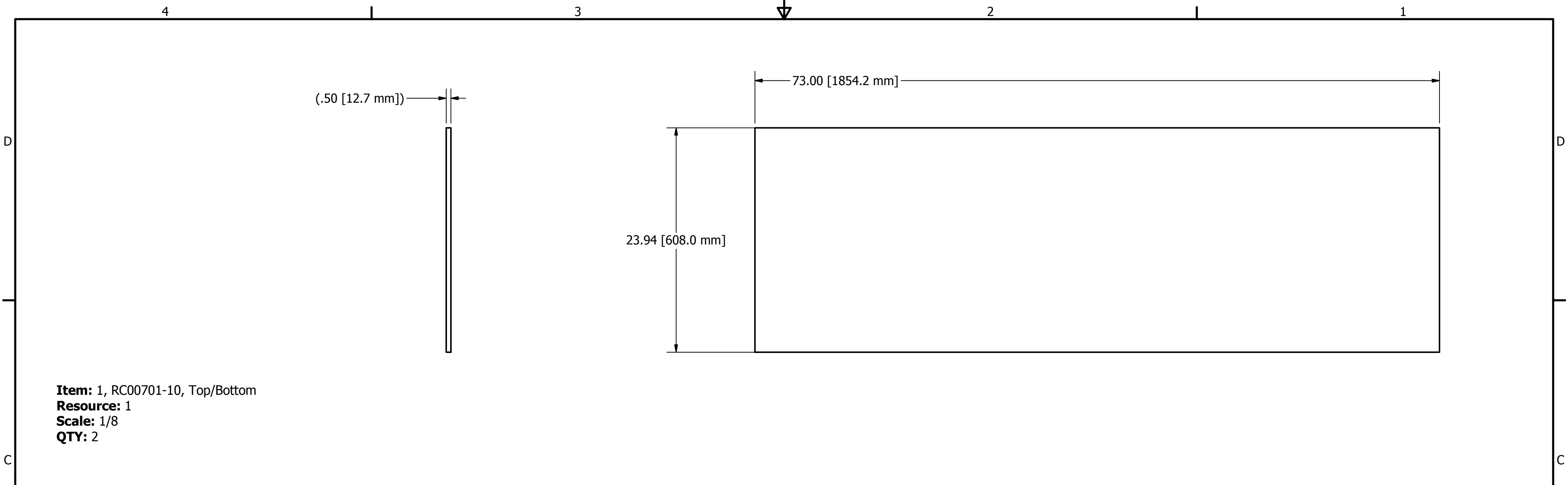

DRAWN mcyr	7/16/2012	FIRST 200 Bedford Street, Manchester, NH 03101 (603) 666-3906 -- FAX (603) 666-3907		
CHECKED				
UNLESS OTHERWISE SPECIFIED		TITLE End Panel Case Insert		
TOLERANCES: (INCHES)				
FRAC.	+/- 1/32	SIZE	DWG NO	REV
.00	+/- .01	C	RC-00701	
.000	+/- .005	SCALE		
ANGULAR	+/- .25 Deg.			SHEET 6 OF 9

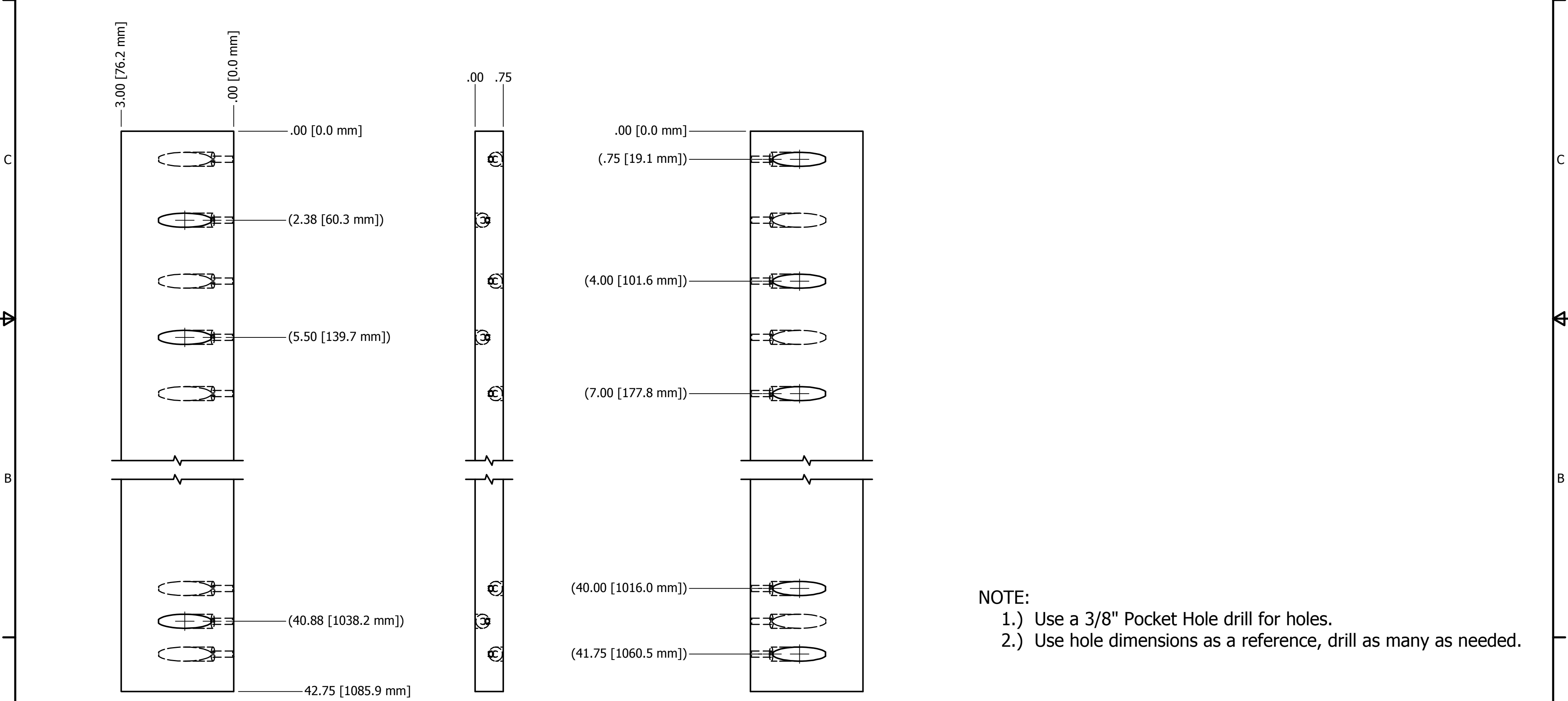
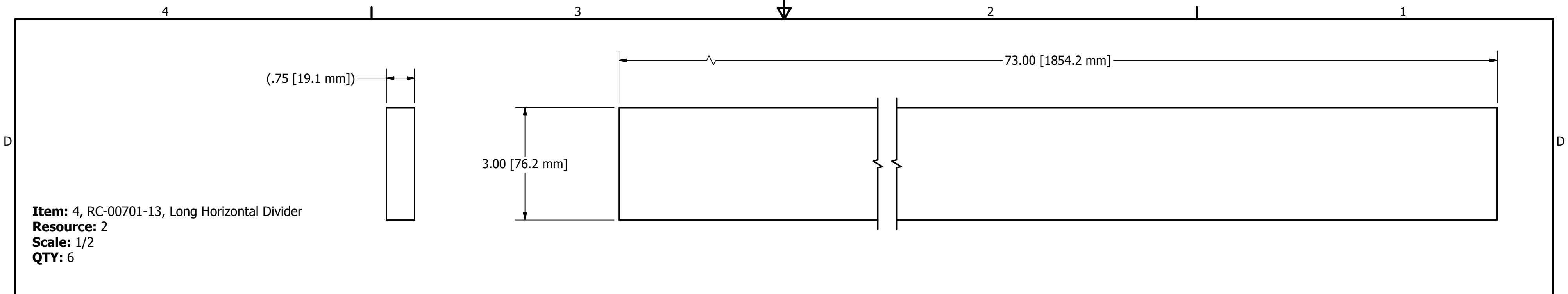

NOTE:
 1.) Use a 3/8" Pocket Hole drill for holes.
 2.) Use hole dimensions as a reference, drill as many as needed.

DRAWN mcyr	7/16/2012	FIRST 200 Bedford Street, Manchester, NH 03101 (603) 666-3906 -- FAX (603) 666-3907		
CHECKED				
UNLESS OTHERWISE SPECIFIED		TITLE		
TOLERANCES: (INCHES)		End Panel Case Insert		
FRAC.	+/- 1/32	SIZE	DWG NO	REV
.00	+/- .01	C	RC-00701	
.000	+/- .005	SCALE	SHEET 7 OF 9	
ANGULAR	+/- .25 Deg.			

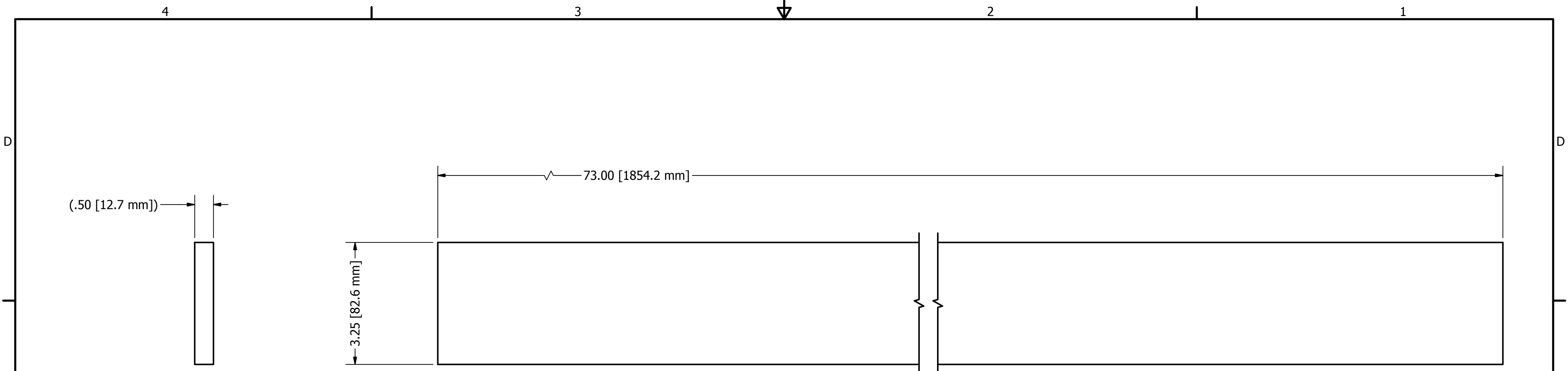

Item: 6, RC-00701-15, Large Bottom Plastic
Resource: 3
Scale: 1/2
QTY: 4

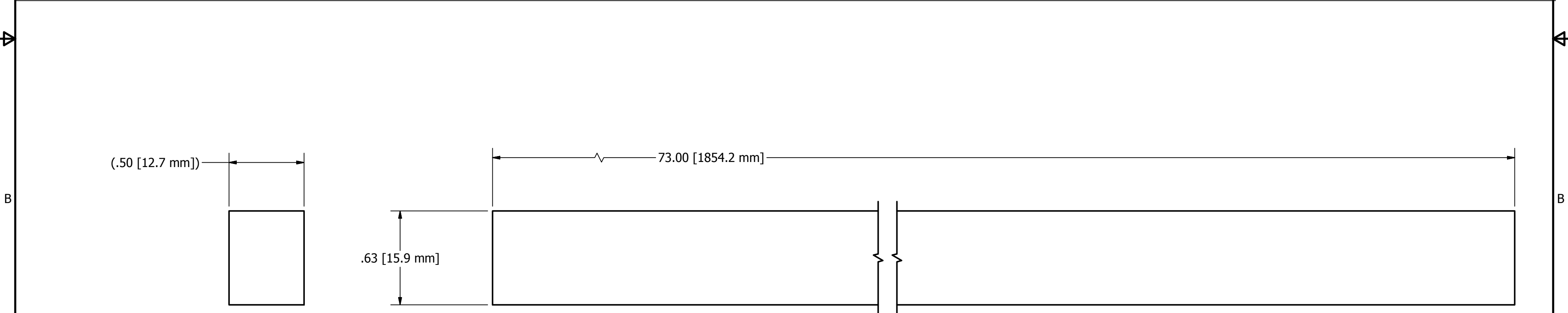

Item: 7, RC-00701-16, Small Bottom Plastic
Resource: 3
Scale: 2:1
QTY: 4

DRAWN mcyr	7/16/2012	FIRST 200 Bedford Street, Manchester, NH 03101 (603) 666-3906 -- FAX (603) 666-3907		
CHECKED				
UNLESS OTHERWISE SPECIFIED		TITLE		
TOLERANCES: (INCHES)		End Panel Case Insert		
FRAC.	+/- 1/32	SIZE	DWG NO	REV
.00	+/- .01	C	RC-00701	
.000	+/- .005	SCALE	SHEET 8 OF 9	
ANGULAR	+/- .25 Deg.			

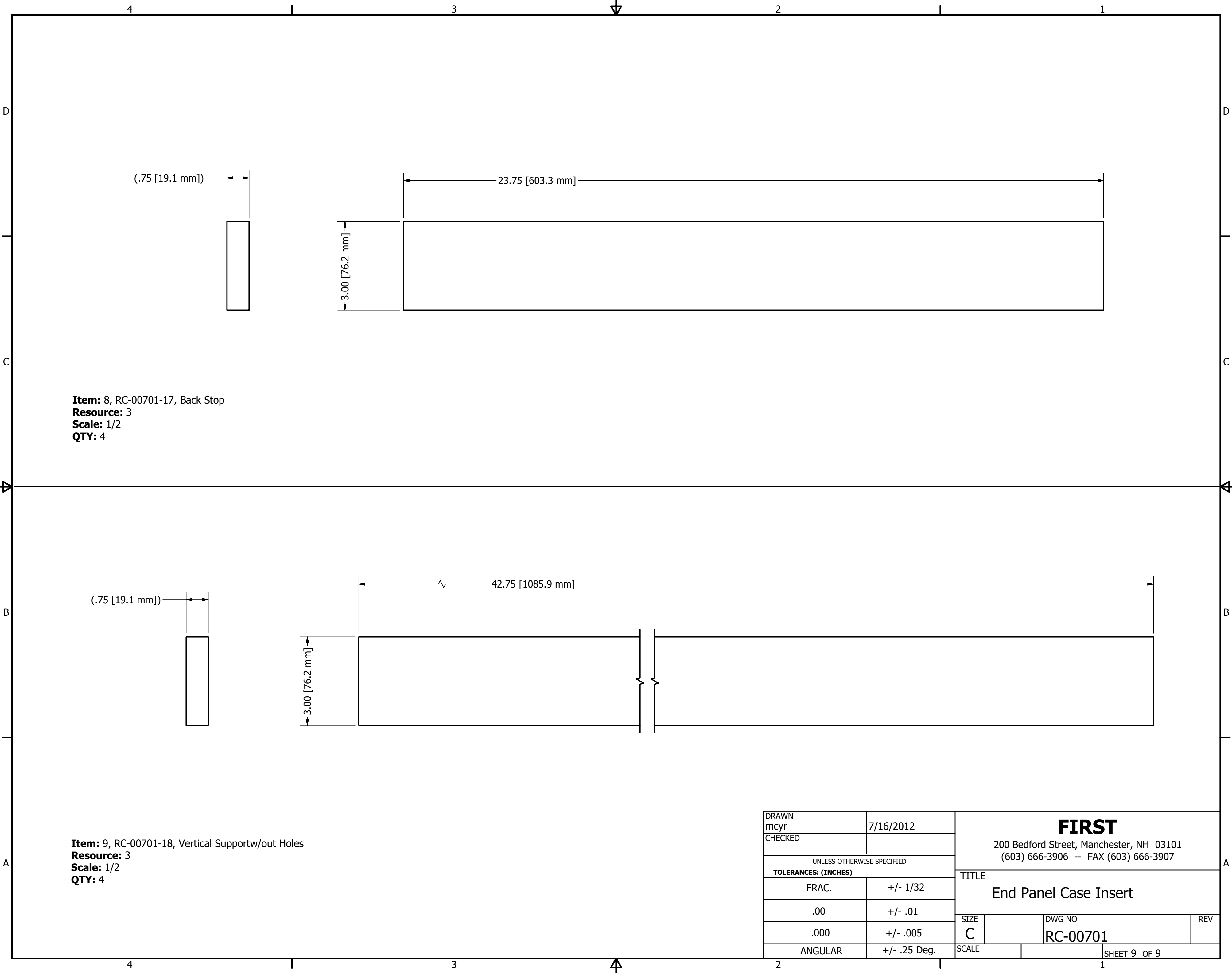

DRAWN mcyr	7/16/2012	FIRST 200 Bedford Street, Manchester, NH 03101 (603) 666-3906 -- FAX (603) 666-3907		
CHECKED				
UNLESS OTHERWISE SPECIFIED		TITLE		
TOLERANCES: (INCHES)		End Panel Case Insert		
FRAC.	+/- 1/32	SIZE	DWG NO	REV
.00	+/- .01	C	RC-00701	
.000	+/- .005	SCALE	SHEET 9 OF 9	
ANGULAR	+/- .25 Deg.			